

Enhanced laser shutter using a hard disk drive rotary voice-coil actuator

R. E. Scholten^{a)}

School of Physics, University of Melbourne, Victoria 3010, Australia

(Received 22 November 2006; accepted 7 January 2007; published online 9 February 2007)

Rotary voice-coil motors from computer hard disk drives make excellent mechanical shutters for light beams. However, the complexity of the necessary electronic driving circuit can hinder their application. A new design is presented here, using a single integrated circuit originally intended for controlling dc motors. A digital input signal switches a unipolar power supply bidirectionally through the voice coil. Short high-current pulses are generated on the transitions to ensure rapid shutter action, while a low holding current reduces the power requirement and heating of the actuator. The circuit can reverse the current to brake the shutter and reduce the impact at the end of its travel. With a focused laser beam, the shutter achieves rise times below 500 ns. A method for producing variable length pulses is also described, demonstrating durations as short as 700 ns.

© 2007 American Institute of Physics. [DOI: 10.1063/1.2437199]

We have previously shown that rotary (swing-arm) voice-coil motors from computer hard disk drives can be used as high-extinction high-speed shutters for laser beams and x-ray sources.¹ Our first implementation demonstrated a shutter speed in excess of 10 mm/ms, switching a focused laser beam in 6 μ s.

While voice-coil actuators are readily available from failed disk drives, the electronics to drive the coil can be problematic. Our original circuit used discrete components to switch a unipolar power supply one way through the actuator coil to close the shutter, and in the reverse direction to open it, depending on a digital input signal. To increase the shutter speed, the circuit generated a short high-current pulse on each transition, but retained only a small holding current to maintain the shutter at the end of its travel, thus avoiding damage to the coil from overheating.

Many of these circuit characteristics are common to dc motor control applications, which typically also require high currents, and the need to reverse the current direction from a unipolar supply. A variety of single-chip motor controller integrated circuits are available, with H-bridge field-effect transistor (FET) cores similar to that used in our discrete circuit. Motor driver circuits often have level conversion circuits to allow direct connection to digital TTL-level signals, current sensing, and built-in protection for overheating, over-current, undervoltage, and shoot-through (i.e., the wrong FETs switching on and short-circuiting).

With the addition of a series RC combination, a motor controller can also produce the high-current transition pulses desirable for shutter operation. Figure 1 shows a simple shutter-driver circuit based on an LMD18200 H-bridge device² and a few passive components. The core of the LMD18200 is a metal-oxide semiconductor field-effect transistor (MOSFET) H-bridge, which connects the unipolar supply to the outputs OUT1,2 with polarity determined by the TTL input level. In the steady state, the coil current is set by the supply voltage and resistor R in series with the coil

resistance, and bipolar capacitor C charges to the potential across R . When the input signal switches, the outputs are reversed and the capacitor rapidly discharges through the coil, with time constant set by C and the coil impedance. A sharp current spike is produced in the coil, up to 6 A, which decays approximately exponentially toward the steady-state value.

Figure 2 shows the optical transmission with the new driver and the shutter described previously,¹ for a laser beam focused with a 40×0.65 NA microscope objective to reduce the waist size to $0.7\ \mu\text{m}$. The driven coil current is also shown, for two values of capacitor C .

Many applications require optical pulses of much shorter duration than was possible with the original shutter design, for example optical imaging of cold atoms.⁴ A V-shaped notch, 2 mm wide by 10 mm deep, was cut into the shutter flag, to transmit a pulse with duration set by the width of the notch where it crosses the laser beam (Fig. 3). The shutter

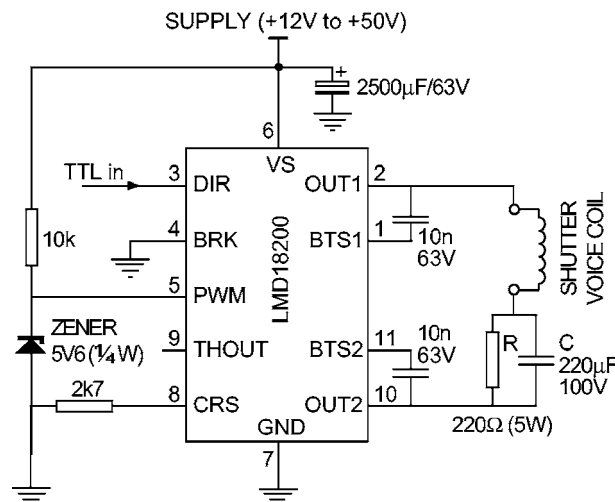

FIG. 1. Bidirectional electronic driving circuit for the shutter using a unipolar supply and a National Semiconductor LMD18200 H-bridge FET motor controller. Note that capacitor C must be bipolar, with voltage rating at least twice the supply voltage. A PCB layout is available (Ref. 3).

^{a)}Electronic mail: r.scholten@physics.unimelb.edu.au

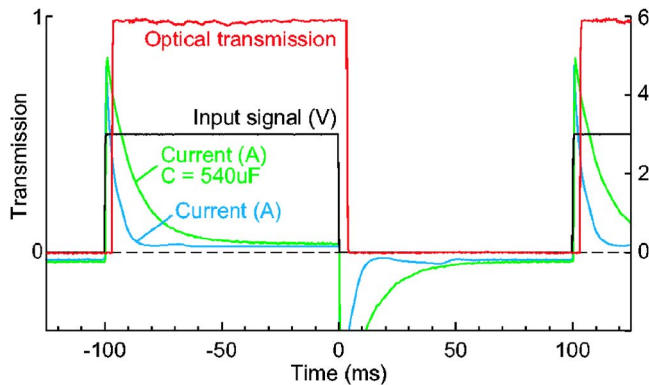

FIG. 2. (Color online) Input signal, optical transmission, and current waveforms. Supply 30 V, $C=220\ \mu\text{F}$, voice-coil resistance $10.5\ \Omega$. Current also shown for $C=540\ \mu\text{F}$.

was mounted to a linear translation stage to precisely control the position and hence pulse duration, from 0.7 to 500 μs , with rise and fall times as low as 450 ns.

The delay time between the input signal and the optical pulse also depends on the relative positioning of the shutter and laser beam. If the shutter, laser, and optics are mounted firmly, the variation in delay time can be quite small. The delay measured for 100 pulses averaged 4.6199 ms with standard deviation of just 180 ns.

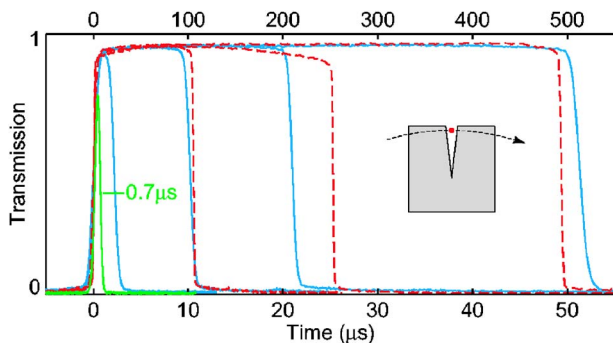

FIG. 3. (Color online) Short duration optical pulses with V-notch shutter (shown inset; notch width 2 mm, depth 10 mm). Laser beam focused with $40\times 0.65\ \text{NA}$ microscope objective. Supply 30 V, $C=220\ \mu\text{F}$. Solid lines are short duration pulses, lower time scale, 0.7 μs (37 V, 540 μF), 2.2, 10, 21, and 51 μs . Dashed lines, upper time scale, and 105, 253, and 494 μs .

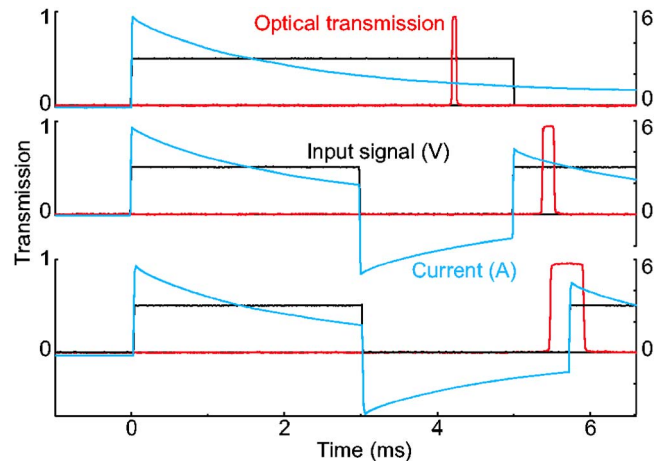

FIG. 4. (Color online) The effect of reverse-current braking. Top, normal operation, 60 μs optical pulse delayed 4.2 ms. Middle, 2 ms reverse-current, 165 μs pulse delayed 5.3 ms. Bottom, 2.7 ms braking, 435 μs pulse delayed 5.5 ms.

The current can be reversed during the traversal to reduce the velocity and end-of-travel impact. Figure 4 shows the effect of reversing the current after 3 ms, for durations of 2 and 2.7 ms, reducing the speed and increasing the optical pulse length accordingly. However, the circuit of Fig. 1 relies on charging capacitor C through the voice coil, and thus cannot immediately provide the full reverse current.

I would like to thank Ekapop Paim and Juergen Eursch for drawing attention to an error in our earlier circuit,⁵ and for suggestions which led to the simpler design presented here. I would also like to thank Sandor Szilagy for his help with circuit construction, and Walther Goethals for drawing our attention to his patent describing an optical shutter based on a linear voice-coil actuator.⁶

¹L. P. Maguire, S. Szilagy, and R. E. Scholten, Rev. Sci. Instrum. **75**, 3077 (2004).

²National Semiconductor. Similar devices are available from other manufacturers, e.g., the Freescale MC33886 and Infineon TLE5205-2.

³<http://optics.ph.unimelb.edu.au/shutter.html>

⁴L. D. Turner, K. F. E. M. Domen, and R. E. Scholten, Phys. Rev. A **72**, 031403(R) (2005).

⁵L. P. Maguire, S. Szilagy, and R. E. Scholten, Rev. Sci. Instrum. **78**, 019903 (2007).

⁶G.R. Edwards, W.A.E. Goethals, and M.R. Keightley, European Patent EP0899595A3, Method and apparatus for actuating a shutter (1999).